

# KIDZ ROCK PRESCHOOL HOME ACTIVITY

## JANUARY 17



# OUT OF THIS WORLD

### Memory Verse:

“Everyone who heard him was amazed.”

LUKE 2:47, NIV

### Bottom Line:

Jesus is amazing.

## HEY FAMILIES,

Our Bible story was about Jesus telling a storm to stop . . . AND IT DID! That’s totally amazing! Everyone who saw Jesus do this was amazed. That’s why we’re learning this Bible verse.

“Everyone (*arms out and around*)

who heard him (*hands behind ears*)

was amazed,’ (*hold hands like binoculars, open and shut*)

Luke 2:47.” (*Open hands like a book.*)

## PRAY TOGETHER!

“Dear God, thank You for sending Jesus to help us when we’re afraid. Help [child’s name] remember that Jesus is with [him/her] when [he/she] is afraid of anything. Jesus is amazing, because He has the power to do anything! You are the best, God, and we love You very much. In Jesus’ name, amen.”

# ACTIVITY 1: ALL IN THE BOAT

**What You Need:** : “All in the Boat” Activity Page, cardstock in two different blues, scissors, large craft sticks, crayons, double-stick tape, and stapler

**What You Do:**

Copy “All in the Boat” on cardstock and cut out. Cut cardstock into eight-inch lengths, one of each shade. Stack the two different blue borders together with the back border higher than the front and staple along each side. Have children color the boat and the disciples. Tape the boat cutout to the craft stick and slide in between the two bulletin borders. Show children how to move the boat back and forth.

**What You Say:**

**BEFORE THE ACTIVITY:** “Do you remember what happened to Jesus and his friends in the boat in our Bible story today? (Pause.) Yes! They got caught in a big storm. Let’s make our own storm today.”

**DURING THE ACTIVITY:** “Pick up the sheet and move your arms up and down. Let’s move our arms slowly at first. The storm is just starting. (Toss the boats and crepe paper strips onto the parachute.)

“Now the storm is getting bigger! Let’s move our arms up and down as quickly as we can to create a big, big storm!”

**AFTER THE ACTIVITY:** “STOP! On the count of three, let’s lay the parachute on the floor. Ready? One, two, three. Great job! Jesus told the storm to stop, and what happened? (Pause.) Yes! The storm stopped because Jesus is out-of-this-world amazing! Who is amazing? Jesus is amazing.”

# ALL IN THE BOAT

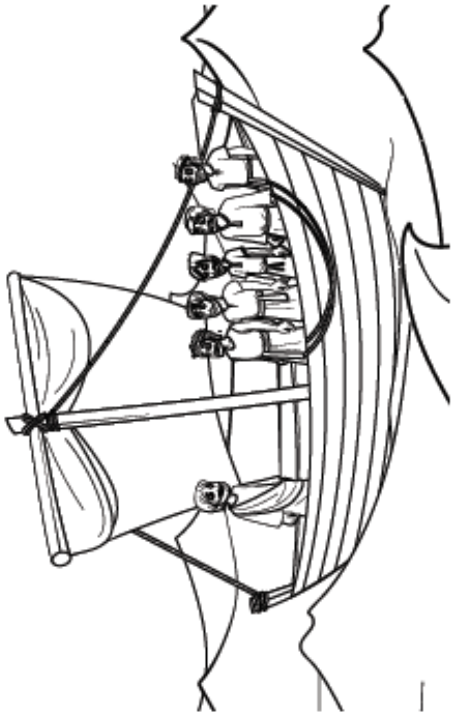

**Jesus is amazing.**  
Calming the Storm.  
Matthew 8:23-27

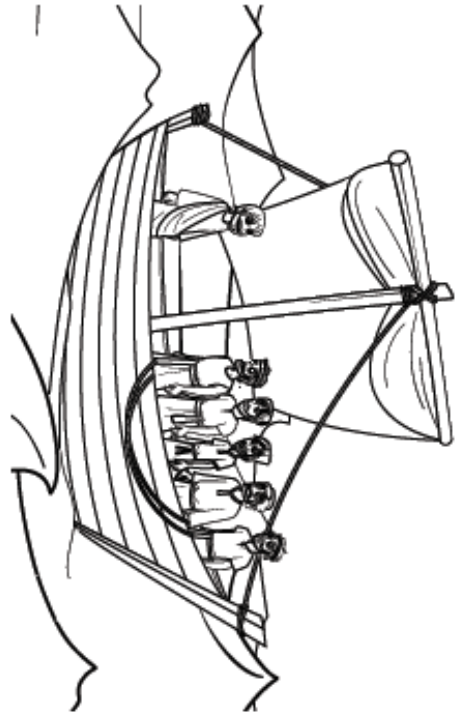

**Jesus is amazing.**  
Calming the Storm.  
Matthew 8:23-27

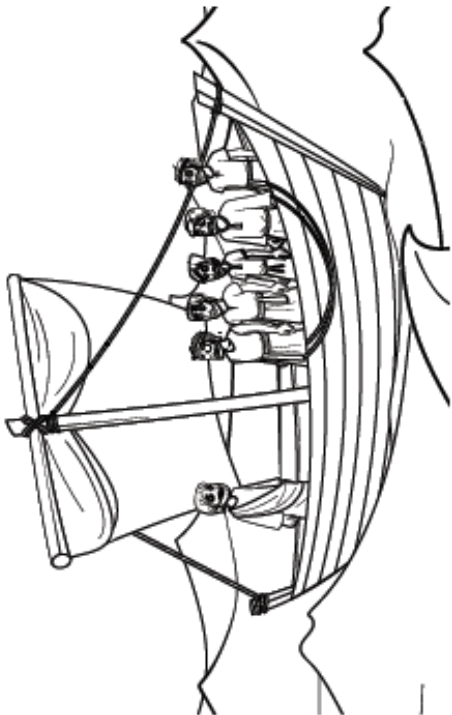

**Jesus is amazing.**  
Calming the Storm.  
Matthew 8:23-27

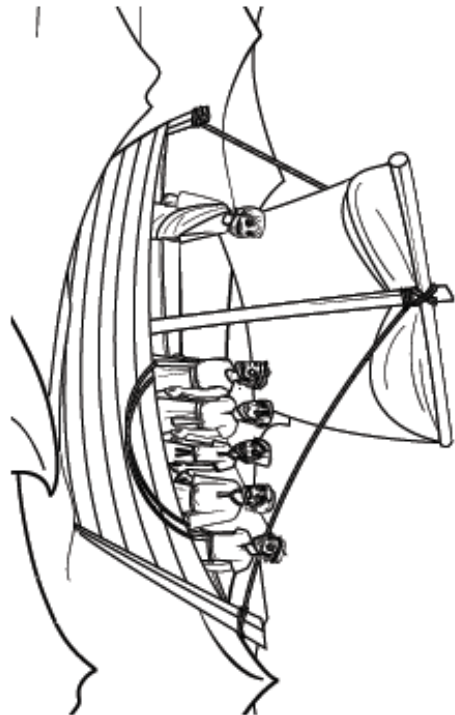

**Jesus is amazing.**  
Calming the Storm.  
Matthew 8:23-27



# ALL IN THE BOAT SAMPLE



**Jesus is amazing.**

Calming the Sea  
Matthew 8:23-27



## ACTIVITY 2: SHEET STORM

**What You Need:** : a flat sheet, blue crepe paper, scissors, and sponge boats

**What You Do:**

Ask the children to gather around the sheet and pick up the section in front of them. Have the children move their arms up and down as you toss the sponge boats and blue crepe paper strips onto the sheet to create a storm. Encourage the children to move their arms faster to create a bigger and bigger storm! Then say, "STOP!"

**What You Say:**

**BEFORE THE ACTIVITY:** "Do you remember what happened to Jesus and his friends in the boat in our Bible story today? (Pause.) Yes! They got caught in a big storm. Let's make our own storm today."

**DURING THE ACTIVITY:** "Pick up the sheet and move your arms up and down. Let's move our arms slowly at first. The storm is just starting. (Toss the boats and crepe paper strips onto the parachute.)

"Now the storm is getting bigger! Let's move our arms up and down as quickly as we can to create a big, big storm!"

**AFTER THE ACTIVITY:** "STOP! On the count of three, let's lay the parachute on the floor. Ready? One, two, three. Great job! Jesus told the storm to stop, and what happened? (Pause.) Yes! The storm stopped because Jesus is out-of-this-world amazing! Who is amazing? Jesus is amazing."



JANUARY 2021

Memory Verse Motions



"Everyone



who heard him



was amazed."



Luke 2:47



OUT OF  
THIS  
WORLD

